

# JUNIORFLUX/COMBIFLUX

For transferring smaller quantities



More than just pumps



# JUNIORFLUX/COMBIFLUX

For transferring smaller quantities

The small drum pumps JUNIORFLUX and COMBIFLUX are especially suitable for pumping comparably small quantities out of containers such as canisters or drums of up to 200 litre or 1 000 litre IBCs. The small outer tube diameter allows pumping even out of narrow openings.

**JUNIORFLUX F 310**  
(see page 4)



**JUNIORFLUX F 314**  
(see page 4)



## JUNIORFLUX

The JUNIORFLUX drum pump unit with its fixed collector motor F 310 (with mains connection) is available with mechanical seal (F 310) and as a sealless type (F 314).

### Technical data

Pump	F 310	F 314
Seal type	with mechanical seal	sealless
Outer tube materials	PP	PP, PVDF, S
Outside diameter in mm	25, 32	25, 32 (PP) 25 (PVDF) 28 (S)
Immersion length	500/700/1 000 mm	
Viscosity max.	250 mPas	
Motor	F 310	
Delivery rate*	max. 47 l/min	max. 57 l/min
Delivery head*	max. 6.8 mwc	max. 8.5 mwc

**FEM 3070**  
(see page 5)



**FBM-B 3100**  
(see page 6)



## COMBIFLUX

The small sealless drum pump COMBIFLUX FP 314 can be combined with the collector motor FEM 3070 (with mains connection) or with the battery motor FBM-B 3100.

### Technical data

Pump	FP 314	
Seal type	sealless	
Outer tube materials	PP, PVDF, S	
Outside diameter in mm	25, 32 (PP) 25 (PVDF) 28 (S)	
Immersion length	500/700/1 000/1 200** mm	
Viscosity max.	250 mPas	
Motor	FEM 3070	FBM-B 3100
Delivery rate*	max. 57 l/min	max. 60 l/min
Delivery head*	max. 8.5 mwc	max. 7 mwc



**COMBIFLUX  
pump FP 314**

\* measured at pump discharge with water (20 °C) depending on outer tube material.

\*\* S ø 28 and PP ø 32 with immersion length 1 200 mm available

# Drum pumps F 310 and F 314/FP 314

with small outer tube diameter



The drum pumps F 310 and F 314/FP 314 are characterised by their small outer tube diameters. This makes these axially acting rotary pumps e.g. especially suitable for pumping out of small and narrow-necked containers.

## F 310 – The small drum pump with mechanical seal

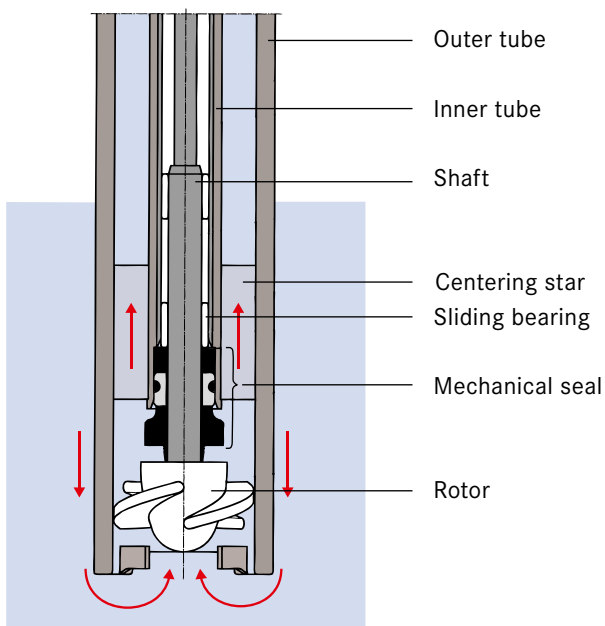

## Description

The mechanical seal of the F 310 seals the inner tube against the media. In this way, the seal prevents the fluid from getting into the inner tube.

## Product features

- ▶ With mechanical seal
- ▶ Small outer tube diameter
- ▶ Low weight

## Examples of media

- ▶ Acids and lyes
- ▶ Fertiliser solutions
- ▶ Cleaning agent solutions
- ▶ Water

## Technical data

- ▶ Outside Ø: 25 mm, 32 mm
- ▶ Outer tube materials: polypropylene, polyvinylidene fluoride, stainless steel
- ▶ Max. viscosity: 250 mPas
- ▶ Max. delivery rate: 47 litres/min
- ▶ Max. delivery head: 6.8 mwc

## F 314/FP 314 – The small sealless drum pump

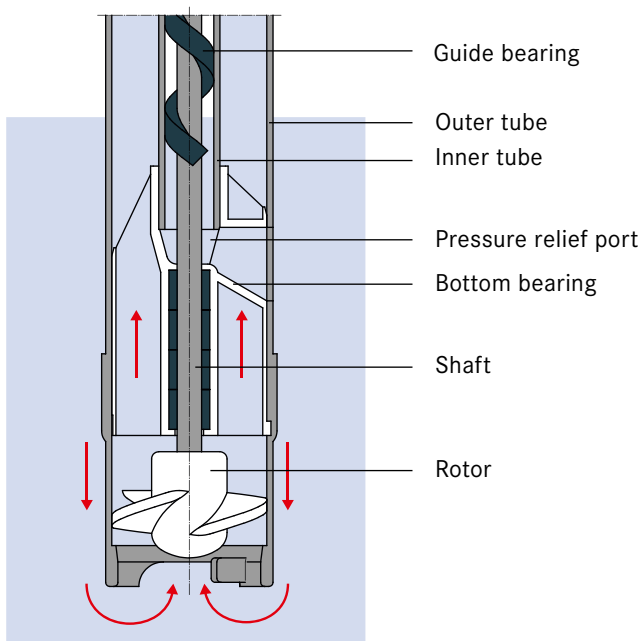

## Description

In the sealless F 314/FP 314, the rotor transports the media along the shaft also into the inner tube where it has the same level as in the container.

During emptying, the media flows off through the relief openings.

## Product features

- ▶ Without mechanical seal
- ▶ Small outer tube diameter
- ▶ Low weight

## Examples of media

- ▶ Also corrosive fluids such as concentrated nitric acid, sulphuric acid, acetic acid

## Technical data

- ▶ Outside Ø: 25 mm, 28 mm, 32 mm
- ▶ Outer tube materials: polypropylene, polyvinylidene fluoride, stainless steel
- ▶ Max. viscosity: 250 mPas
- ▶ Max. delivery rate: 60 litres/min
- ▶ Max. delivery head: 8.5 mwc

# JUNIORFLUX

with fixed collector motor F 310

The small drum pump JUNIORFLUX with its fixed collector motor is available with a mechanical seal (F 310) and as a sealless version (F 314). It is especially suitable for pumping comparably small quantities out of containers such as canisters or drums of up to 200 litres. The small outer tube diameter allows pumping even out of narrow openings.

## JUNIORFLUX F 310 PP



Transferring of small quantities with the JUNIORFLUX pump kit.

\* measured at pump discharge with water (20 °C) depending on outer tube material.

### Product features

- ▶ With mains connection
- ▶ Powerful collector motor (with brushes)
- ▶ Available in two seal types
- ▶ Ergonomic design handle
- ▶ Low weight
- ▶ Small outer tube diameter
- ▶ Holding hook for hand nozzle at the pump discharge
- ▶ With integrated holder for the pump
- ▶ Also available as a pump kit

### Advantages

- ▶ Also suitable for transferring smaller quantities
- ▶ Can pump out of narrow-necked containers
- ▶ Minimal force required to change drums
- ▶ With mains connection – enables very long operating times
- ▶ High operational safety due to overload cut-out switch
- ▶ Easy single-hand operation
- ▶ Hand nozzle always quickly at hand due to holding hook
- ▶ Low storage space required

### Technical data

#### Pump:

- ▶ Seal type: F 310 with mechanical seal (see page 3 for more)  
F 314 sealless (see page 3 for more)
- ▶ F 310 outer tube material: polypropylene
- ▶ F 314 outer tube materials: polypropylene/ polyvinylidene fluoride/stainless steel
- ▶ Delivery rate: 17 - 57 l/min\*
- ▶ Max. viscosity: 250 mPas
- ▶ Max. delivery head: 8.5 mwc
- ▶ Immersion length: 500/700/1 000 mm
- ▶ Pump discharge connection
- ▶ Outside diameter: 25 - 32 mm (depending on media)

#### Motor F 310:

- ▶ Type: Collector motor
- ▶ Protection class: IP 24
- ▶ Speed adjustment: 2 steps
- ▶ Weight: 1.5 kg
- ▶ Voltage: 110 V, 50 - 60 Hz; 240, 230 V, 50 Hz
- ▶ 230 V version tested to German VDE and GS
- ▶ 5 m cable with 2-pole connector (cables and connectors specific to country)

# COMBIFLUX

with removable collector motor FEM 3070



The small sealless drum pump COMBIFLUX FP 314 can be combined with the collector motor FEM 3070 (with mains connection). It is of a modular design, so that several pumps can be operated in series with one motor. Like the JUNIORFLUX, the COMBIFLUX is especially suitable for pumping comparably small quantities out of containers such as canisters or drums of up to 1 000 litre IBCs. The small outer tube diameter allows pumping even out of narrow openings.

COMBIFLUX with FEM 3070

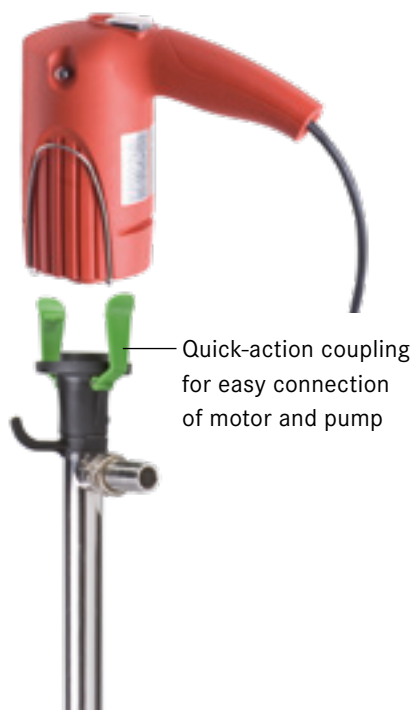

## Product features

- ▶ Collector motor and pump connected by means of quick-action coupling
- ▶ With mains connection
- ▶ Powerful collector motor (with brushes)
- ▶ Ergonomic design handle
- ▶ Small outer tube diameter
- ▶ Low overall weight
- ▶ Holding hook for hand nozzle at the pump discharge
- ▶ With integrated holder for the pump

## Advantages

- ▶ **Motor easily removable**
- ▶ **Several pumps can be operated in series with one motor**
- ▶ **Also suitable for transferring smaller quantities**
- ▶ **Enables pumping out of narrow-necked containers difficult to access**
- ▶ **Minimal force required to change drums**
- ▶ **Easy single-hand operation**
- ▶ **With mains connection – enables very long operating times**
- ▶ **High operational safety due to overload cut-out switch**
- ▶ **Hand nozzle always quickly at hand due to holding hook**
- ▶ **Low storage space required**



COMBIFLUX – Transferring of various fluids with several pumps and a tethered motor FEM 3070.

\* measured at pump discharge with water (20 °C) depending on outer tube material.

## Technical data

**Pump FP 314** (see page 3 for more):

- ▶ Outer tube materials: polypropylene/ polyvinylidene fluoride/stainless steel
- ▶ Delivery rate: 27 - 57 l/min\*
- ▶ Max. viscosity: 250 mPas
- ▶ Max. delivery head: 8.5 mwc
- ▶ Immersion length: 500/700/1 000/1 200 mm (depending on version)
- ▶ Pump discharge connection
- ▶ Outside diameter: 25 - 32 mm (depending on media)

**Motor FEM 3070:**

- ▶ Type: collector motor
- ▶ Protection class: IP 24
- ▶ Speed adjustment: 2 steps
- ▶ Weight: 1.5 kg
- ▶ Voltage: 110 V, 50 - 60 Hz; 230 V, 50 - 60 Hz
- ▶ 5 m cable with 2-pole connector (cables and connectors specific to country)

# COMBIFLUX

with removable battery motor FBM-B 3100

With the FBM-B 3100, the world's first maintenance-free battery motor for pumps, the COMBIFLUX FP 314 becomes a battery-operated pump and can therefore also be used where no mains supply is available or a cable installation is problematic or not desired. In this combination, the pump impresses with its astonishing high delivery rate for such a small pump. The FBM-B 3100 engine with powerful replacement battery convinces with its long battery service life and a very short charging time.

## COMBIFLUX with FBM-B 3100



## Product features

- ▶ No mains connection required
- ▶ Brushless motor
- ▶ Motor with quickly replaceable storage battery
- ▶ New, more powerful battery
- ▶ Very short charging times
- ▶ Constant speed over entire battery service life
- ▶ Battery motor and pump connected by means of quick-action coupling
- ▶ Ergonomic design motor handle
- ▶ Small outer tube diameter
- ▶ Low overall weight
- ▶ Protection class IP 44

## Advantages

- ▶ Can be used immediately and flexibly – without installing cables, independent of power outlets – also outdoors
- ▶ Maintenance-free and wear-free – saves costs
- ▶ A 200-litre drum can be emptied within just three minutes (at 15 000 rpm)
- ▶ Battery runtime up to 200 min (at 5 000 rpm)
- ▶ Seventeen 200-litre drums can be emptied with one storage battery (at 5 000 rpm)
- ▶ Delivery rate will not drop near end of battery service life
- ▶ Last speed setting active when switched on again
- ▶ Minimal interruption of work due to replaceable storage battery
- ▶ Replaceable storage battery – recharged within 55 minutes
- ▶ Motor easily removable
- ▶ Several pumps can be operated in series with one motor
- ▶ Also suitable for transferring smaller quantities
- ▶ Enables pumping out of narrow-necked containers difficult to access
- ▶ Externally ventilated motor for a better motor protection



FBM-B 3100 battery motor – the solution where cables are problematic or not desired.



High mobility due to battery motor.

#### Technical data

**Pump FP 314** (see page 3 for more):

- ▶ Type of seal: sealless
- ▶ Outer tube materials: polypropylene/  
polyvinylidene fluoride/stainless steel
- ▶ Delivery rate: 12 - 60 l/min\*
- ▶ Max. viscosity: 250 mPas
- ▶ Delivery head: 7 mwc
- ▶ Immersion length: 500/700/1 000/1 200 mm  
(depending on version)
- ▶ Outside diameter: 25 - 32 mm (depending on media)



Variable delivery rate due to stepless speed adjustment.



Minimal interruption of work due to replaceable battery.

#### Motor FBM-B 3100:

- ▶ Type: externally ventilated, brushless d.c. motor
- ▶ Drive: battery
- ▶ Protection class: IP 44
- ▶ Speed adjustment: infinitely variable
- ▶ Weight: 1.2 kg

#### Battery + charger:

- ▶ Battery type: lithium-ion
- ▶ Battery voltage: 18 V
- ▶ Battery capacity: 2.5 Ah
- ▶ Charger: 100 - 120 V, 50 - 60 Hz; 220 - 240 V, 50 - 60 Hz
- ▶ Type: fast charger
- ▶ Charging time: 55 min



Fully recharged within 55 minutes.

\* measured at pump discharge with water (20 °C)  
depending on type of pump.



More than just pumps

Today the FLUX name is recognised around the globe as the trademark for top standards in pump technology. Everything started with the invention of the electric drum pump in 1950. Nowadays FLUX has an extensive range of products each of which can be customized. FLUX pumps are used for example in the chemical and pharmaceutical industries; in machinery and plant engineering as well as companies in electroplating, wastewater treatment and the food sector.

Whether single-product or system solution – FLUX quality is synonymous with a long service life, excellent economy and maximum safety.

In addition to the excellent product quality FLUX customers appreciate the superb level of expertise our staff has to offer as well as their genuine customer focus.

These days FLUX-GERÄTE GMBH supplies pumps to almost 100 countries around the globe.