

Models: PF25132HH, PF25134HH, PF25132HV, PF25134HV



**Submersible
Dewatering
2" NPT & 3" NPT Female**



CSA[®]
C US
File No. 239053

Features:

Power-Flo pumps are compact, lightweight powerful Portable Electric Submersible Pumps. They are whisper quiet and will perform in any position. Power-Flo pumps can be staged in series for higher head applications.

Power-Flo in-line design assures maximum heat transferred to the pumped liquid. Power-Flo pumps can operate in up to 140°F (60°C) temperature water. Power-Flo design provides the coolest operating motor for maximum life. Consult the factory prior to pumping fluids other than water for professional instructions

- **DISCHARGE CASE:** Aluminum, Hard Anodized, 3" w/2" adapter
- **DIFFUSER:** Aluminum, Hard Anodized
- **SUCTION CASE:** Aluminum, Hard Anodized, with wear resistant polyurethane liner
- **FRAME & OUTER CASE:** Aluminum, Hard Anodized
- **WEAR PLATE:** Polyurethane
- **PUMP SHAFT:** Stainless Steel
- **IMPELLER:** Hardened 17-4 Stainless Steel
- **HARDWARE:** Stainless Steel
- **O-RINGS:** Buna-N
- **SEAL:** Tandem mechanical, Oil lubricated
 - **INBOARD:** Carbon/Ceramic/Buna-N, Hardware-300 Series Stainless
 - **OUTBOARD:** Silicon Carbide/Silicon Carbide/Buna-N Hardware - 300 Series Stainless
- **STRAINER:** Stainless Steel, 1/4" Holes
- **UPPER BEARING:** Single Row, Shielded, Ball, Pre lubricated high- temperature grease, Load: Radial
- **LOWER BEARING:** Single Row, Shielded, Ball, Pre lubricated high-temperature grease, Load: Radial & Thrust
- **CORD ENTRY:** 50 Ft., 12/4 SOOW, with Strain Relief and Pressure Grommet for Sealing
- **MOTOR:** Class H insulation, VPI
- **CONTROL:** NEMA 3R Rainproof, w/Start capacitor, start relay and Circuit Breaker
- **OPTIONAL:** NEMA-4 Weathertight Control, NEMA-4 Dual Float Control, Anti-Sludge Strainer, Carrying Handles
- **WARRANTY:** 1 year

**⚠ WARNING: CANCER AND REPRODUCTIVE HARM-
WWW.P65WARNINGS.CA.GOV**

Vacuum Pressure Impregnation "VPI" Sealed Insulation System

VPI motor enhancement system was developed to greatly extend the winding life expectancy of an electric motor. The motor stator is loaded into a pressure vessel and immersed in the specialty selected varnish. All gas pockets located within the stator are evacuated under vacuum. The varnish is drawn into the stator core, completely occupying all voids in the winding.

Following a series of processes, ending in a controlled bake, the winding is 100% impregnated and sealed. VPI is greatly superior to the "dip and bake" method which may provide only 50% to 70% of effective insulation leaving voids and air pockets. VPI provides 100% solid mass structure which provides the greatest mechanical strength and a cooler running motor due to superior heat dissipation.



Power-Flo Pumps & Systems

a Power-Flo Technologies company

877-24PUMPS • fax: 516-812-6897 • www.powerflopumps.com

Models: PF25132HH, PF25134HH, PF25132HV, PF25134HV

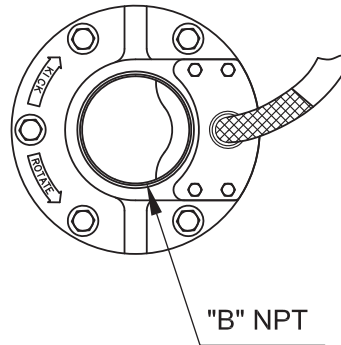
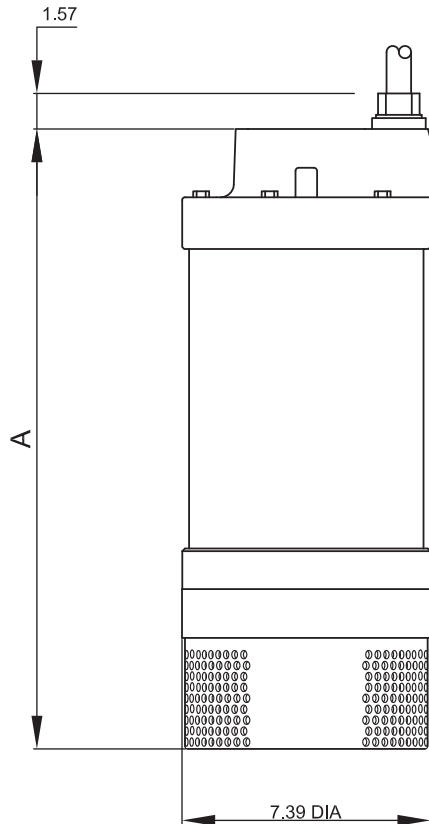

Control Box (1PH) 2H NEMA 3R - RAINPROOF CONTROL

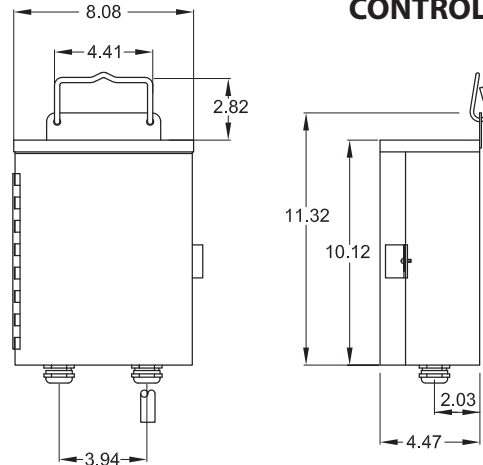

DIM "A" (inches)	NPT Discharge
21.44	2" & 3"

MODEL #	HP	VOLT/ PH	Hz	RPM	NEMA START CODE	FULL LOAD AMPS	LOCKED ROTOR AMPS	MAX CORD LENGTH (FT)	NEMA 3R CONTROL BOX
HH SERIES W/ NEMA 3R RAINPROOF CONTROL									
PF25132HH	2.5	230/3	60	3450	J	6.8	49.2	500	V500834
PF25134HH	2.5	460/3	60	3450	J	3.4	24.6	2075	V250834
HV SERIES W/ NEMA 3R RAINPROOF CONTROL									
PF25132HV	2.5	230/3	60	3450	J	7.8	49.2	500	V500834
PF25134HV	2.5	460/3	60	3450	J	3.9	24.6	2075	V250834

Notes: Add "LC" to model number for Less Control Box

IMPORTANT APPLICATION INFORMATION !

- 1) FOR THOSE APPLICATIONS SPECIFIED AS CLASS I DIVISION II HAZARDOUS LOCATIONS THIS PUMP AND CONTROL SUPPLIED ARE NOT APPROPRIATE FOR HAZARDOUS LOCATIONS.
- 2) INSTALLATIONS SUCH AS DECORATIVE WATER FEATURES MUST BE INSTALLED IN ACCORDANCE WITH THE NATIONAL ELECTRIC CODE ANSI/ NFPA 70. THIS PUMP IS NOT INTENDED FOR USE IN RECREATIONAL WATER PARKS, SWIMMING POOLS, OR INSTALLATIONS IN WHICH HUMANS ARE IN CONTACT WITH THE PUMPED FLUID.

MODEL	POWER CORD WEIGHT	CONTROL BOX WEIGHT	PUMP ONLY WEIGHT	SHIPPING WEIGHT
2-1/2 hp	13.2 lbs	8.8 lbs	49.5 lbs	80 lbs



Power-Flo Pumps & Systems

a Power-Flo Technologies company

877-24PUMPS • fax: 516-812-6897 • www.powerflopumps.com

Dewatering Pumps - 2-1/2HP - 3450RPM - 60Hz

Models: PF25132HH, PF25134HH, PF25132HV, PF25134HV

Dewatering Pumps - 2-1/2HP - 3450RPM - 60Hz

