

Model	MX-F402		
	CFV	RFV	KKV
1 Front Casing	CFRETFE		
2 Impeller	CFRETFE		
3 Rear Casing	CFRETFE		
4 Magnet capsule	CFRETFE		
5 O-ring	FKM ¹		
6 Spindle	High Purity Alumina Ceramic		SiC
7 Bearing	Carbon	PTFE	SiC
8 Rear thrust	CFRETFE		
9 Mouth ring	PTFE		SiC
10 Thrust/Liner ring	Alumina Ceramic		SiC
11 Lock pin	CFRETFE		

1 EPDM and AFLAS® o-ring also available

MX-F402 2 HP

- Engineered to meet the most severe operating conditions.
- When fitted with a carbon bearing, the MX will allow for brief periods of dry running.
- The MX Series is the first resin magnet pump that uses a Split Volute Pump Casing that forms a vortex chamber.
- Patented Self-radiating structure – Heat dispersion holes force the liquid to circulate around the spindle and bearing.

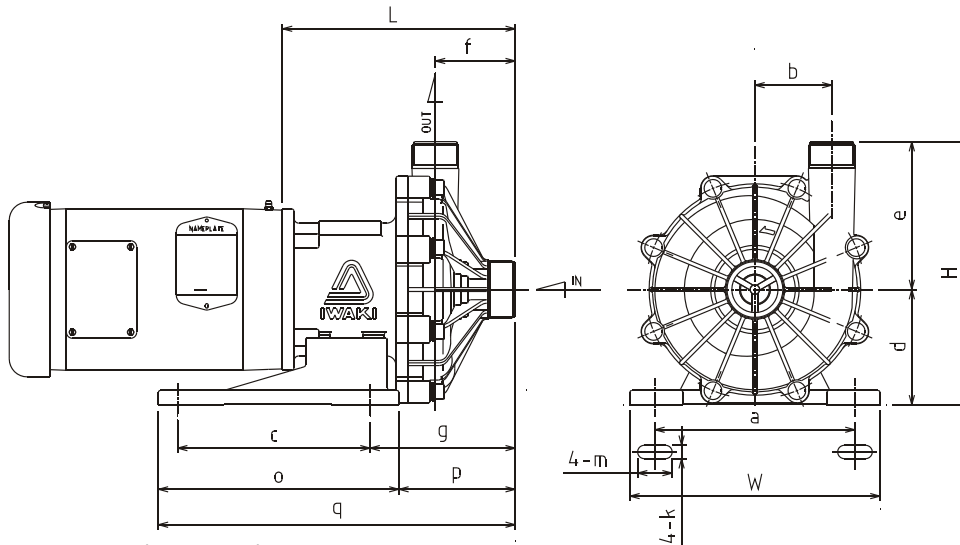

Dimensions (in inches)

a	b	c	d	e	f	g	k	m	o	p	q	W	H	L
8.19	3.15	7.87	4.72	6.06	3.27	5.94	0.47	1.42	9.84	4.76	14.61	10.24	10.78	9.53

Specifications

Suction x Discharge	Max Discharge pressure	Max Flow	Specific gravity	Weight (less motor)
2" x 1.5"	70 FT	120 GPM	1.2	29.8 lbs

MX-F402

